

CATALOG	DESCRIPTION
HSD13	1U, 3 INCH EXTENSION W/COVER, BLACK

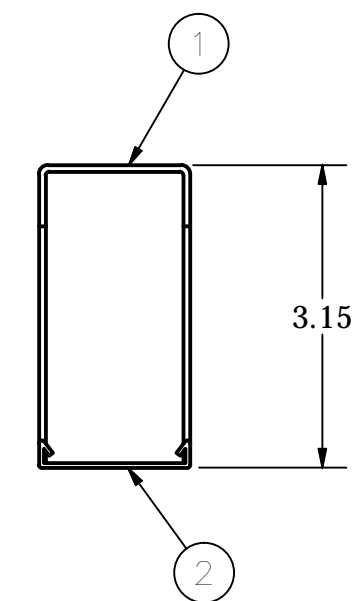
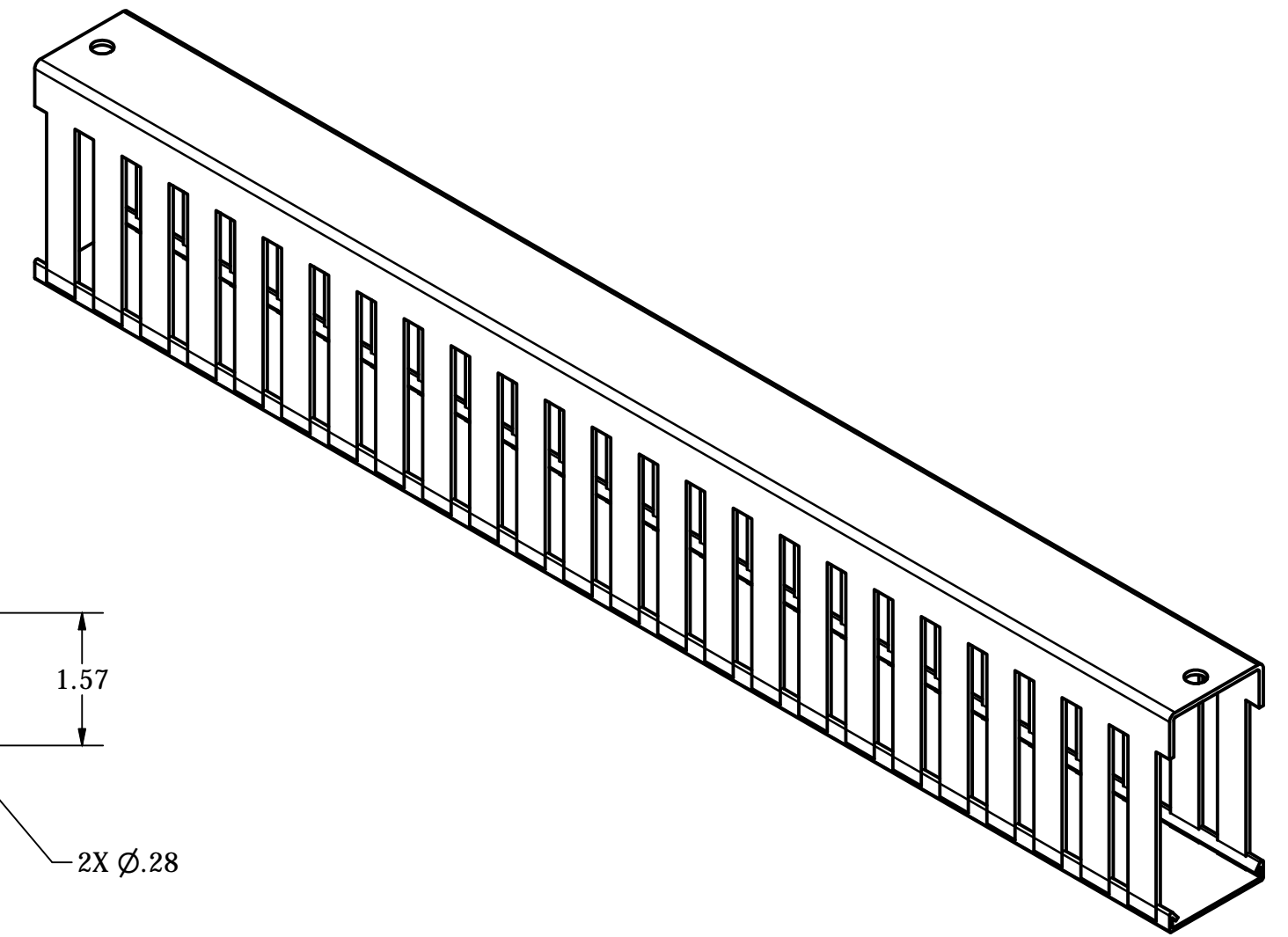
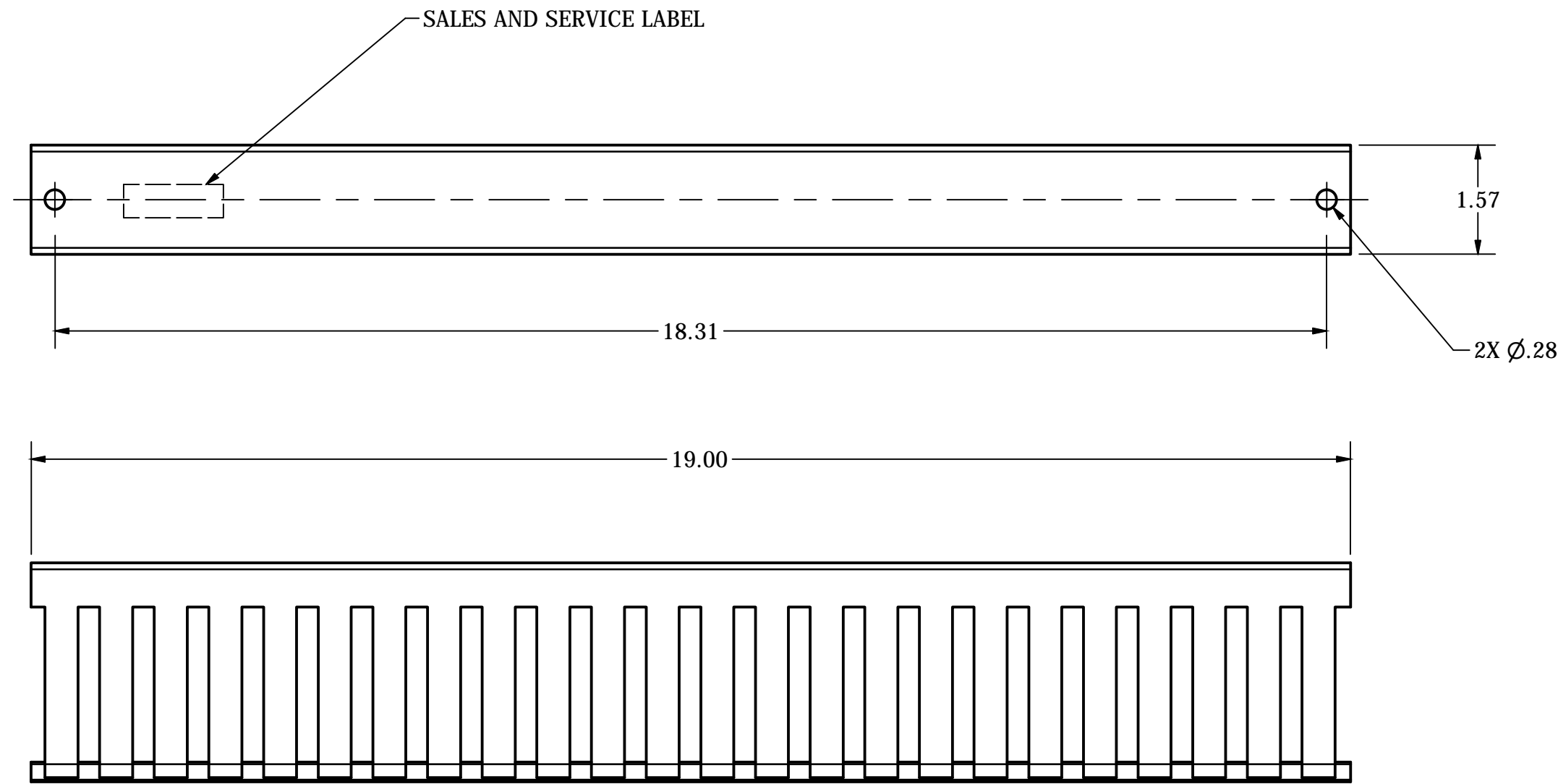

NOTES:

1. MATERIAL: RIGID PVC, BLACK
2. SPECIFICATIONS SUBJECT TO CHANGE WITHOUT NOTICE.

4	INSTRUCTIONS	1
3	#12-24 HARDWARE PACK	1
2	COVER	1
1	BASE	1
ITEM	DESCRIPTION	QTY.

Created on INVENTOR	DIMENSIONING AND TOLERANCE PER ANSI Y14.5M-1982 UNLESS OTHERWISE SPECIFIED, DIMENSIONS ARE IN INCHES (MM). TOLERANCES: XX = ±.01 (.25) .XXX = ±.005 (.127) .XXXX = ±.0025 (.0635) ANGLE TOL ±1°		PROJECT REFERENCE: 2012-014			Hubbell Premise Wiring HUBBELL INCORPORATED (Delaware) 23 CLARA DRIVE, SUITE 103 MYSTIC, CT 06355	
	IN ACCEPTING OUR DRAWINGS, BLUEPRINTS, OR SUPPORTING DOCUMENTATION FOR QUOTATION OR OTHER PURPOSES, YOU AGREE NOT TO DISCLOSE TO OTHERS THE IDEAS, INFORMATION, OR DESIGNS SHOWN HEREIN, AND THAT YOU WILL MAKE NO USE OF SAME WITHOUT PERMISSION		MATERIAL: PVC			TITLE: 1U PLASTIC WIRE DUCT	
			DRAWN BY: D.O'CONNOR 5/27/14		SIZE	DRAWING NO.	REV.
			CHECKED BY:		C	HWS14428C	2
		APPROVED BY:		SCALE: NTS		SHEET 1 OF 1	

2	19545	11/4/14	REVISED TABLE	DPO	
1	19461	5/27/14	INITIAL RELEASE	DPO	MMA
REV.	ECN	DATE	DESCRIPTION	CHG BY	APPD BY